



STONE COLD SOLUTIONS

LASTING GREEN SOLUTIONS FOR THE FOOD SERVICE INDUSTRY

CONFORMS TO
NSF/ANSI 7



- 5 year standard warranty
- All stainless steel construction, including fully welded 1/2" stainless steel drain line
- Total thermal performance in high ambient conditions
- No moving parts for increased reliability
- Highest efficiency unit on the market
- Patent Pending cold track system for efficient product cooling
- Compatible with 404A and Glycol systems
- Custom sizes available

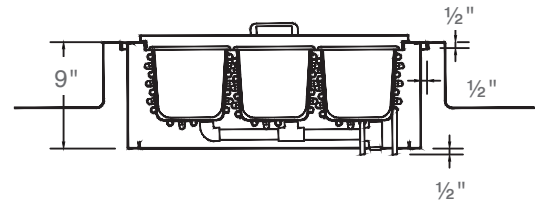
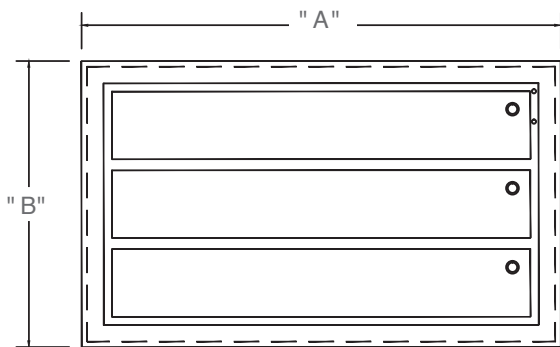

SIDE VIEW: FLAT MOUNTED*

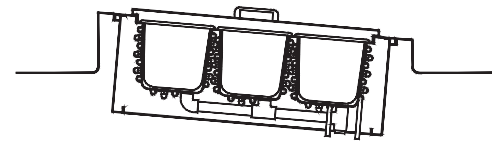
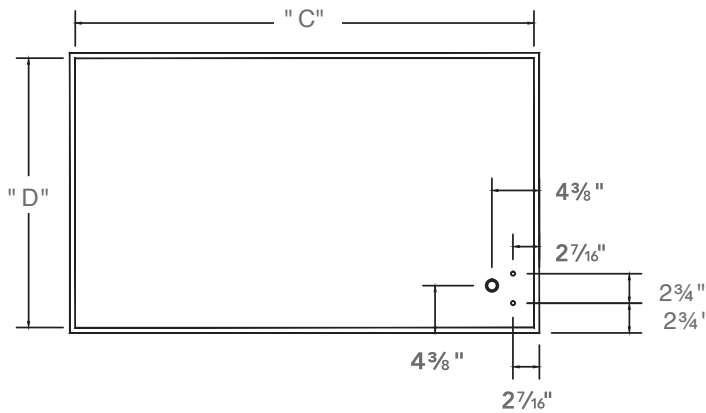

SIDE VIEW: MOUNTED AT 5 DEG. PITCH*

*drawings not to scale

MODEL NUMBER	1/8 PANS CAPACITY	BTU/HR	A	B	C	D
SCSCR-24-1	3	450	24 1/4"	11 1/2"	23 1/4"	10 1/2"
SCSCR-24-2	6	675	24 1/4"	18 3/4"	23 1/4"	17 3/4"
SCSCR-24-3	9	1125	24 1/4"	25 3/4"	23 1/4"	24 3/4"
SCSCR-44-1	6	900	43 1/4"	11 1/2"	42 1/4"	10 1/2"
SCSCR-44-2	12	1350	43 1/4"	18 3/4"	42 1/4"	17 3/4"
SCSCR-44-3	18	2250	43 1/4"	25 3/4"	42 1/4"	24 3/4"
SCSCR-69-1	10	1500	68 3/4"	11 1/2"	67 3/4"	10 1/2"
SCSCR-69-2	20	2250	68 3/4"	18 3/4"	67 3/4"	17 3/4"
SCSCR-69-3	30	3750	68 3/4"	25 3/4"	67 3/4"	24 3/4"